

JARDIM DE INFÂNCIA LUIZ GAMA

ATIVIDADES COMPLEMENTARES

PRÉ II

PROFESSORES :DANIELA C. MINOZZO (Regente da Turma)

GILBERTO BET (Informática)

CARLA RAVARENA (Artes)

LORECI POZZER (Dança)

CARLOS ALEXANDRE PICCHI (Educação Física)

RAQUEL ADRIANA SOUZA (Inglês)

Coronel Martins, 16 de novembro de 2020

NOME: _____ DATA: ___/___/2020.

Olá crianças, pais e responsáveis. Nessa apostila faremos uma pequena revisão avaliativa. Portanto peço aos responsáveis que **não** façam as atividades por sua criança, e sim, apenas as auxiliie. Deixe ela escrever do jeitinho dela. Grata pela compreensão. Prof Daniela.

AS VOGAIS









ESCREVA A LETRA INICIAL DO NOME DE CADA DESENHO.

				
<input type="text"/>	<input type="text"/>	<input type="text"/>	<input type="text"/>	<input type="text"/>
				
<input type="text"/>	<input type="text"/>	<input type="text"/>	<input type="text"/>	<input type="text"/>
				
<input type="text"/>	<input type="text"/>	<input type="text"/>	<input type="text"/>	<input type="text"/>

A - E - I - O - U NÓS SOMOS AS VOGAIS

CADÊ AS VOGAIS?

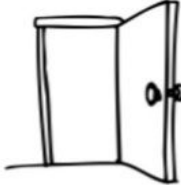
NESTA ATIVIDADE, TODAS AS VOGAIS SUMIRAM DAS PALAVRAS. OBSERVE AS FIGURAS E COMPLETE AS PALAVRAS COM AS VOGAIS QUE FALTAM.

 P T	 T M T
 X C R	 P P C
 C R R	 C B R
 P R T	 B L D

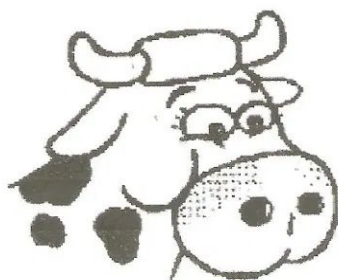

V.....C.....



V.....L.....



B.....L.....

NÚMEROS

COMPLETE AS LACUNAS COM OS NÚMEROS QUE ESTÃO FALTANDO.

QUEM ESTÁ FALTANDO? 1 2 3 4 5 6 7 8 9 10

1		2		4		
2						
3	6		8		10	
...						





















1	1			4		
2						
3		7			10	
...						



1	1		3		5	
2						
3		7			9	
...						

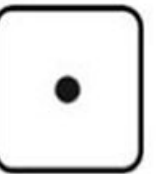

VAMOS SOMAR? CONTE QUANTAS BOLINHAS HÁ EM CADA DUPLA DE DADOS E COLOQUE O RESULTADO.

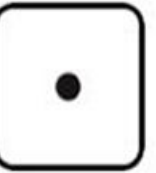
 +  = <u> </u>	 +  = <u> </u>
 +  = <u> </u>	 +  = <u> </u>
 +  = <u> </u>	 +  = <u> </u>
 +  = <u> </u>	 +  = <u> </u>
 +  = <u> </u>	 +  = <u> </u>

NOME: _____ DATA: ___/___/2020.

OBSERVE O ALFABETO E SEPRE AS VOGAIS DAS CONSOANTES. VOCÊ JÁ SABE QUE **A - E - I - O - U** SÃO VOGAIS, ENTÃO FICA FÁCIL SABER QUAIS SÃO AS CONSOANTES. VAMOS LÁ?

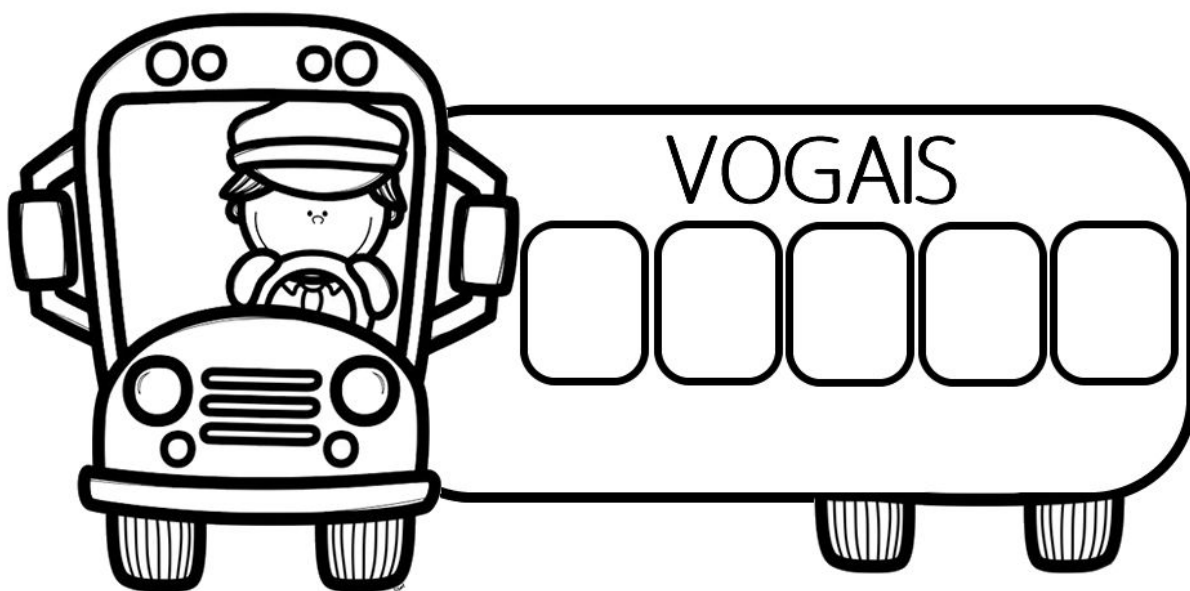



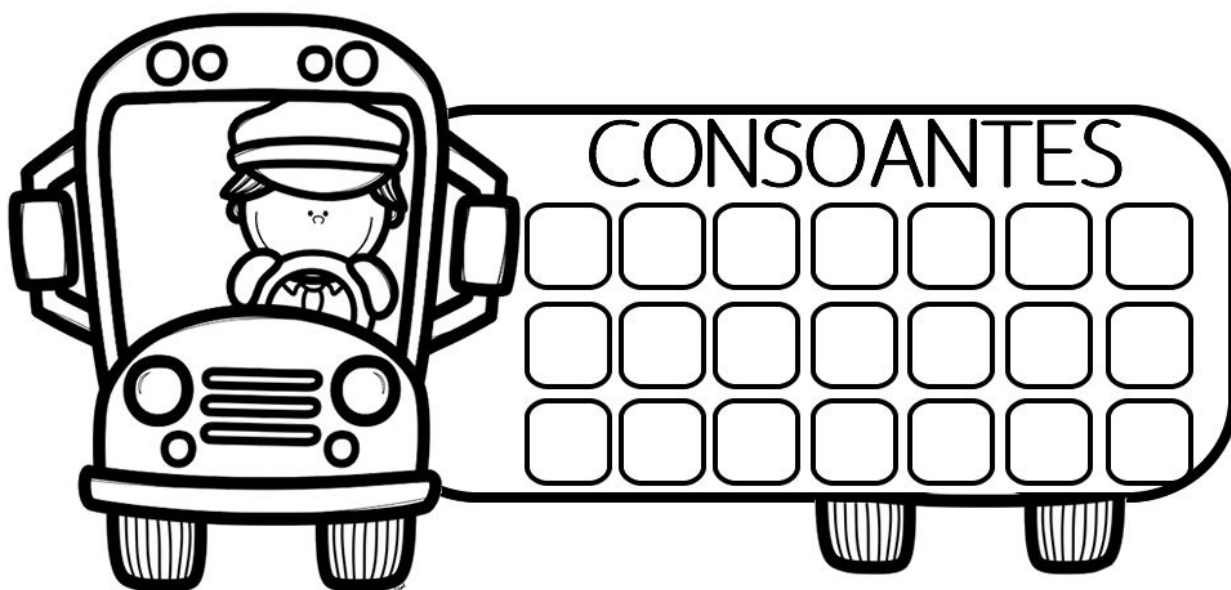





A B C D E F G H I J K L M
N O P Q R S T U V W X Y Z



CADÊ AS CONSOANTES?

NESTA ATIVIDADE, TODAS AS CONSOANTES SUMIRAM DAS PALAVRAS. OBSERVE AS FIGURAS E COMPLETE AS PALAVRAS COM AS CONSOANTES QUE FALTAM.

 <table border="1"><tr><td> </td><td>A</td><td> </td><td>E</td><td>I</td><td>A</td></tr></table>		A		E	I	A	 <table border="1"><tr><td> </td><td>E</td><td> </td><td> </td><td>I</td><td> </td><td>O</td></tr></table>		E			I		O	
	A		E	I	A										
	E			I		O									
 <table border="1"><tr><td> </td><td>A</td><td> </td><td>A</td><td> </td><td>O</td></tr></table>		A		A		O	 <table border="1"><tr><td> </td><td> </td><td>I</td><td> </td><td>A</td><td> </td><td>A</td></tr></table>			I		A		A	
	A		A		O										
		I		A		A									
 <table border="1"><tr><td> </td><td> </td><td>A</td><td> </td><td> </td><td>A</td></tr></table>			A			A	 <table border="1"><tr><td> </td><td> </td><td> </td><td>O</td><td> </td><td>E</td><td> </td><td>A</td></tr></table>				O		E		A
		A			A										
			O		E		A								
 <table border="1"><tr><td> </td><td> </td><td>A</td><td> </td><td>A</td><td> </td><td>O</td></tr></table>			A		A		O	 <table border="1"><tr><td> </td><td> </td><td>A</td><td> </td><td> </td><td>Ã</td><td>O</td></tr></table>			A			Ã	O
		A		A		O									
		A			Ã	O									



_ A _ U



_ E R E _ A



_ E _ A

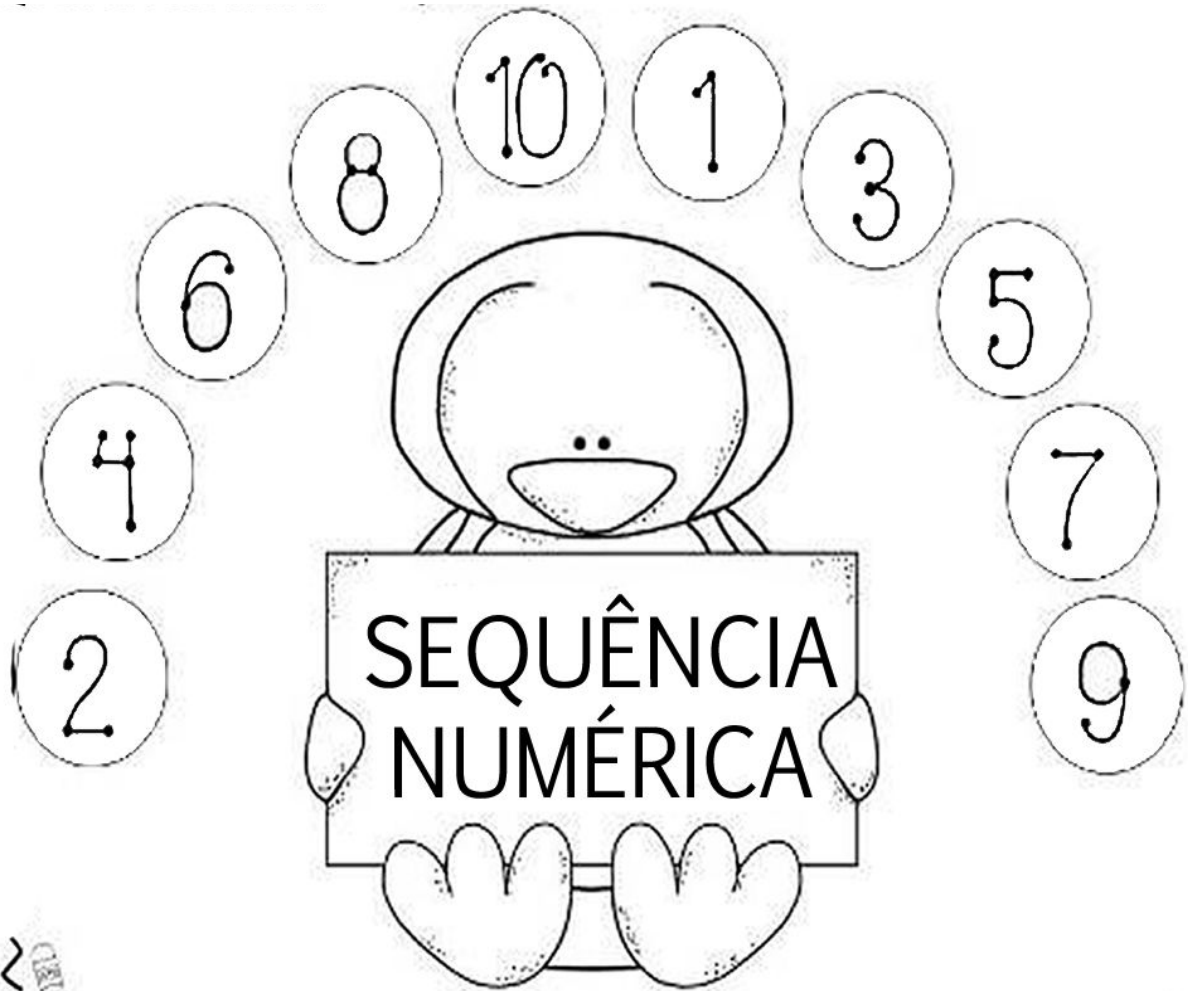

NOME: _____ DATA: ___/___/2020.

OS NUMERAIS ESTÃO FORA DE ORDEM, COPIE-OS ABAIXO, SEGUINDO A SEQUÊNCIA CORRETA.

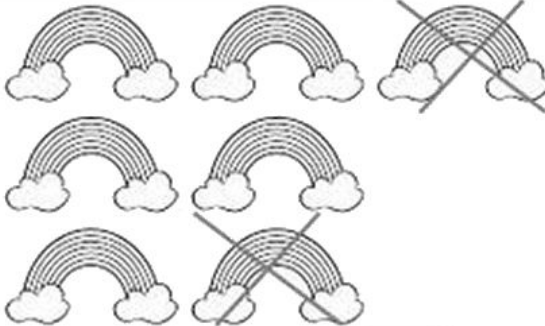
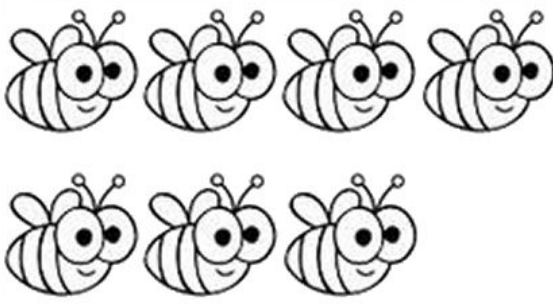

VAMOS DIMINUIR? FAÇA COMO NO EXEMPLO DOS ARCOS-ÍRIS, RISQUE A QUANTIDADE INDICADA E VEJA QUANTOS SOBRAM EM CADA CONJUNTO:

 <p>$7 - 2 = \boxed{5}$</p>	 <p>$7 - 3 = \square$</p>
---	--

 <p>$7 - 1 = \square$</p>	 <p>$8 - 6 = \square$</p>
--	---

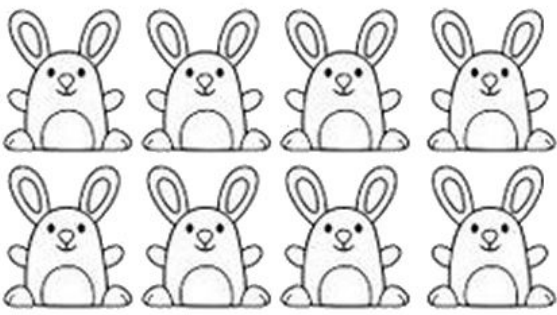
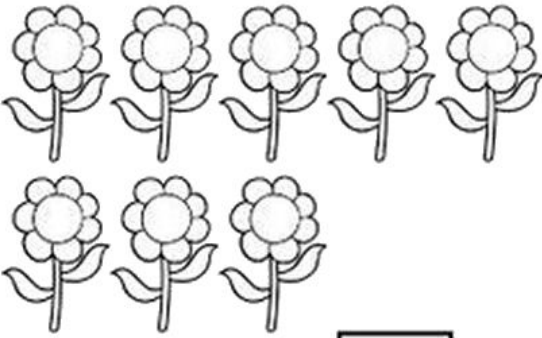
 <p>$8 - 2 = \square$</p>	 <p>$8 - 4 = \square$</p>
---	--



$9 - 4 = \dots$

© SHANTROO

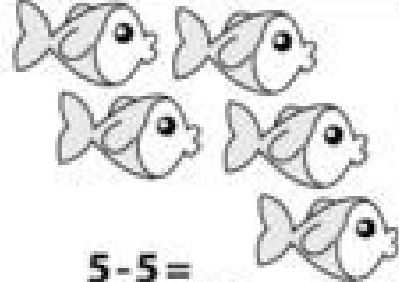

$5 - 5 = \dots$

INTERPRETAÇÃO DE TEXTO

LEIA PARA A CRIANÇA O PEQUENO TEXTO ABAIXO. DEPOIS FAÇA A LEITURA DAS PERGUNTAS E SOLICITE PARA QUE A CRIANÇA PINTE A RESPOSTA CORRETA, OU, AQUELA QUE ELA ACHA QUE É.

A FOCA VIU A BOLA

MAS O GATO A PEGOU

LEVOU-A PARA CASA

JUNTO AO DADO A COLOCOU!

ISABEL CRISTINA S. SOARES



1 - QUEM VIU A BOLA FOI:



2 - QUEM PEGOU A BOLA FOI:



3 - O GATO LEVOU A BOLA PARA:













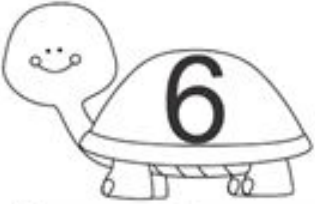
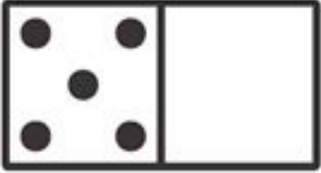

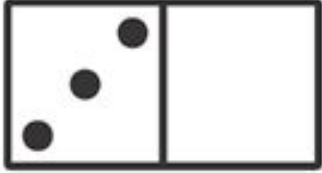
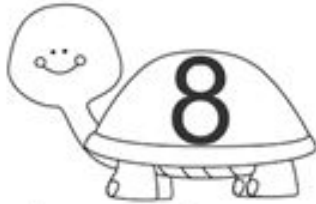
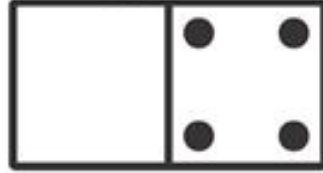
4 - A BOLA FOI COLOCADA JUNTO AO:

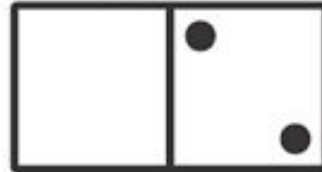
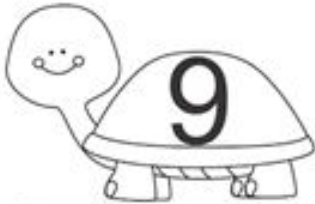
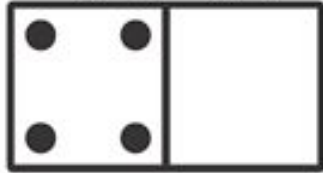

ESCREVE A LETRA INICIAL E A LETRA FINAL DE CADA PALAVRA:

	LETRA INICIAL <input type="text"/>	PALAVRA ABELHA	LETRA FINAL <input type="text"/>		LETRA INICIAL <input type="text"/>	PALAVRA ELEFANTE	LETRA FINAL <input type="text"/>
	LETRA INICIAL <input type="text"/>	PALAVRA PATO	LETRA FINAL <input type="text"/>		LETRA INICIAL <input type="text"/>	PALAVRA COBRA	LETRA FINAL <input type="text"/>
	LETRA INICIAL <input type="text"/>	PALAVRA CAVALO	LETRA FINAL <input type="text"/>		LETRA INICIAL <input type="text"/>	PALAVRA DINOSSAURO	LETRA FINAL <input type="text"/>
	LETRA INICIAL <input type="text"/>	PALAVRA JACARÉ	LETRA FINAL <input type="text"/>		LETRA INICIAL <input type="text"/>	PALAVRA LOBO	LETRA FINAL <input type="text"/>

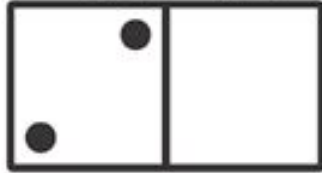

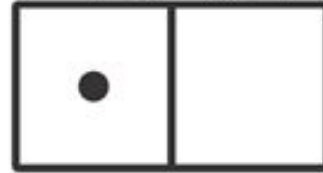

COMPLETE AS PEÇAS DE DOMINÓ DE MODO QUE A SOMA TOTAL SEJA A MESMA QUE APARECE NO CASCO DA TARTARUGA.

LEIA:

0 - 1 - 2 - 3 - 4 - 5 - 6 - 7 - 8 - 9 - 10 - 11
- 12 - 13 - 14 - 15 - 16 - 17 - 18 - 19 - 20

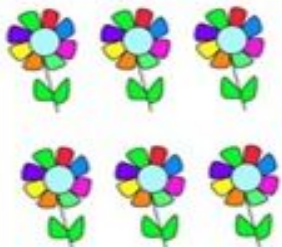
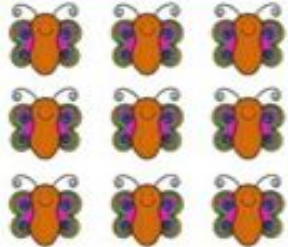
CONTE QUANTOS ELEMENTOS HÁ EM CADA CONJUNTO E PINTE O NUMERAL CORRESPONDENTE:

			
5 6 7	4 6 8	9 6 7	10 11 12
			
9 8 7	6 9 8	13 12 11	8 9 10

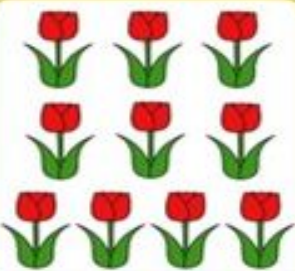
© Sue's Study Room 2015

© Sue's Study Room 2015

17 5 19	6 18 3	14 8 20
		
19 3 12	10 5 20	16 7 13
		

QUAL É O CERTO?

APENAS UMA DAS FIGURAS COMEÇA COM A LETRA EM DESTAQUE. QUAL É ?
PINTE APENAS A FIGURA QUE COMEÇA COM A LETRA E DEPOIS ESCREVA O NOME
DA FIGURA. DEIXE A CRIANÇA ESCREVER DO JEITINHO QUE ELA ACHA QUE É.

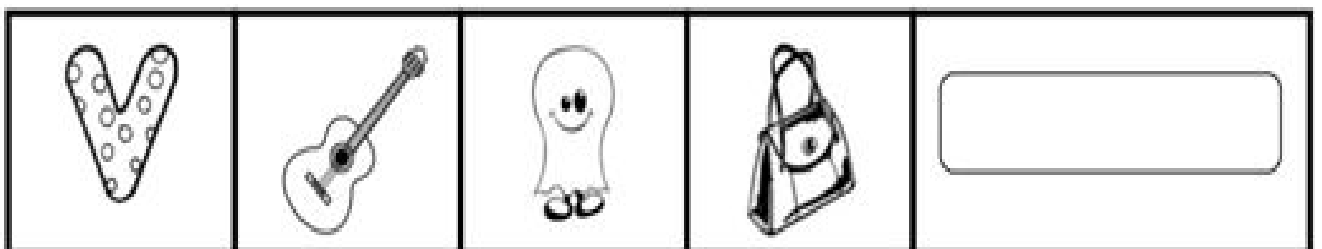
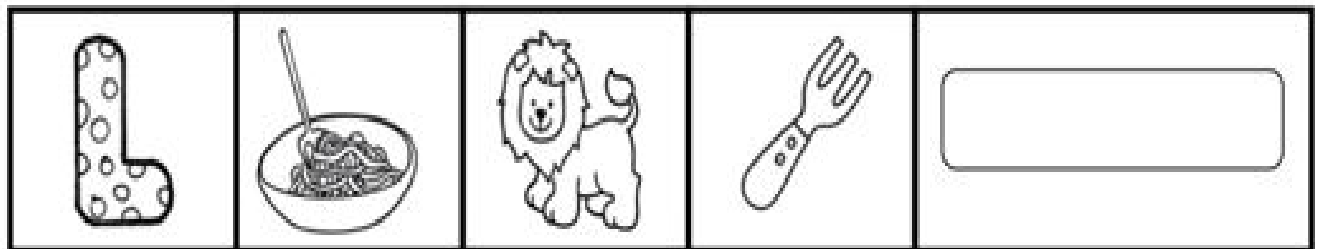
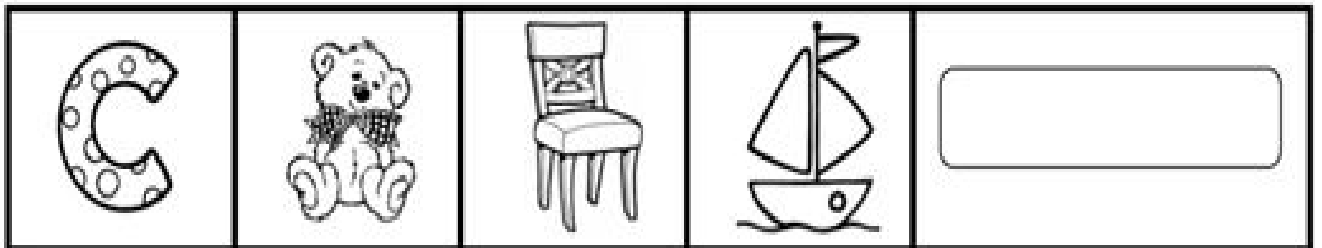
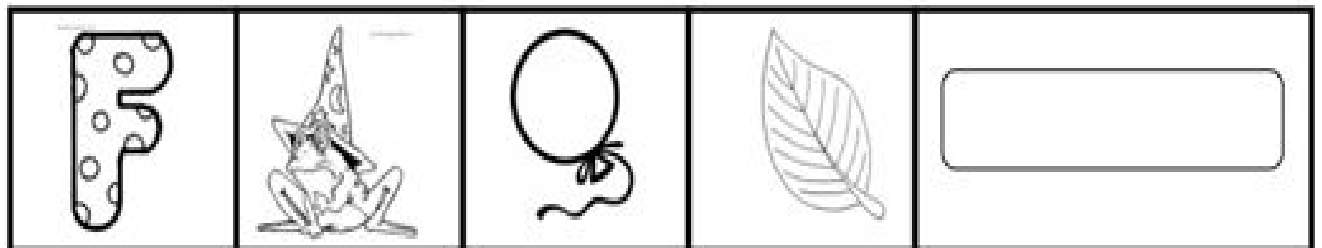
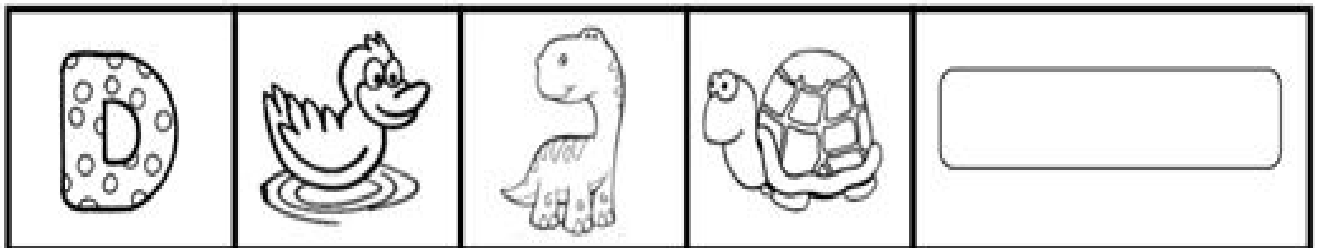

→ OBSERVE O ALFABETO:



A B C D E F G H I J K L M N O P Q R S T U V W X Y Z

→ QUEM VEM ANTES?

		B			F			I			M
		P			T			V			Z

→ QUEM VEM DEPOIS?







	A			D			G			J	
	N			Q			U			X	

AGORA ESCREVA AS VIZINHAS:

	J				S	
	N				H	
	E				X	
	A				D	
	Q				V	

NOME: _____ DATA: ___/___/2020.

DESCUBRA OS NÚMEROS ESCONDIDO EM CADA VEGETAL E ESCREVA CADA NUMERAL NO QUADRINHO CORRESPONDENTE:

0	1		2	4
	6	7		9
10		12	13	
15	16		18	19













AGORA, ESCREVA A SEQUÊNCIA NUMÉRICA ATÉ 19:

0	1								

SENHORES PAIS, LEIA AS FRASES PARA SEU(A) FILHO(A) E PEÇA PARA ELE(A) ENUMERAR AS FRASES DE ACORDO COM OS DESENHOS:



- O menino está com frio.
- A menina comprou uma roupa nova.
- Eu bebi suco de laranja.
- O sapo pulou.
- As crianças brincam.
- Ele chutou a bola.
- A menina gosta de nadar.
- Ele leu o jornal.
- A menina encontrou sua amiga.

MEU CORPO

Quantos você tem?

- | | | | |
|----------|----------------------|---|-------------|
| Eu tenho | <input type="text"/> |  | Cabeça |
| Eu tenho | <input type="text"/> |  | Olhos |
| Eu tenho | <input type="text"/> |  | Boca |
| Eu tenho | <input type="text"/> |  | Dedos |
| Eu tenho | <input type="text"/> |  | Mãos |
| Eu tenho | <input type="text"/> |  | Braços |
| Eu tenho | <input type="text"/> |  | Dedos do pé |
| Eu tenho | <input type="text"/> |  | Orelhas |
| Eu tenho | <input type="text"/> |  | Joelhos |

PARA REALIZAR ESSA ATIVIDADE, VÁ PARA A ÚLTIMA PÁGINA: **ATIVIDADE 1**
RECORTE AS IMAGENS DA PARTE DO CORPO E COLE-AS ABAIXO, IDENTIFICANDO CADA PARTE DO CORPO.

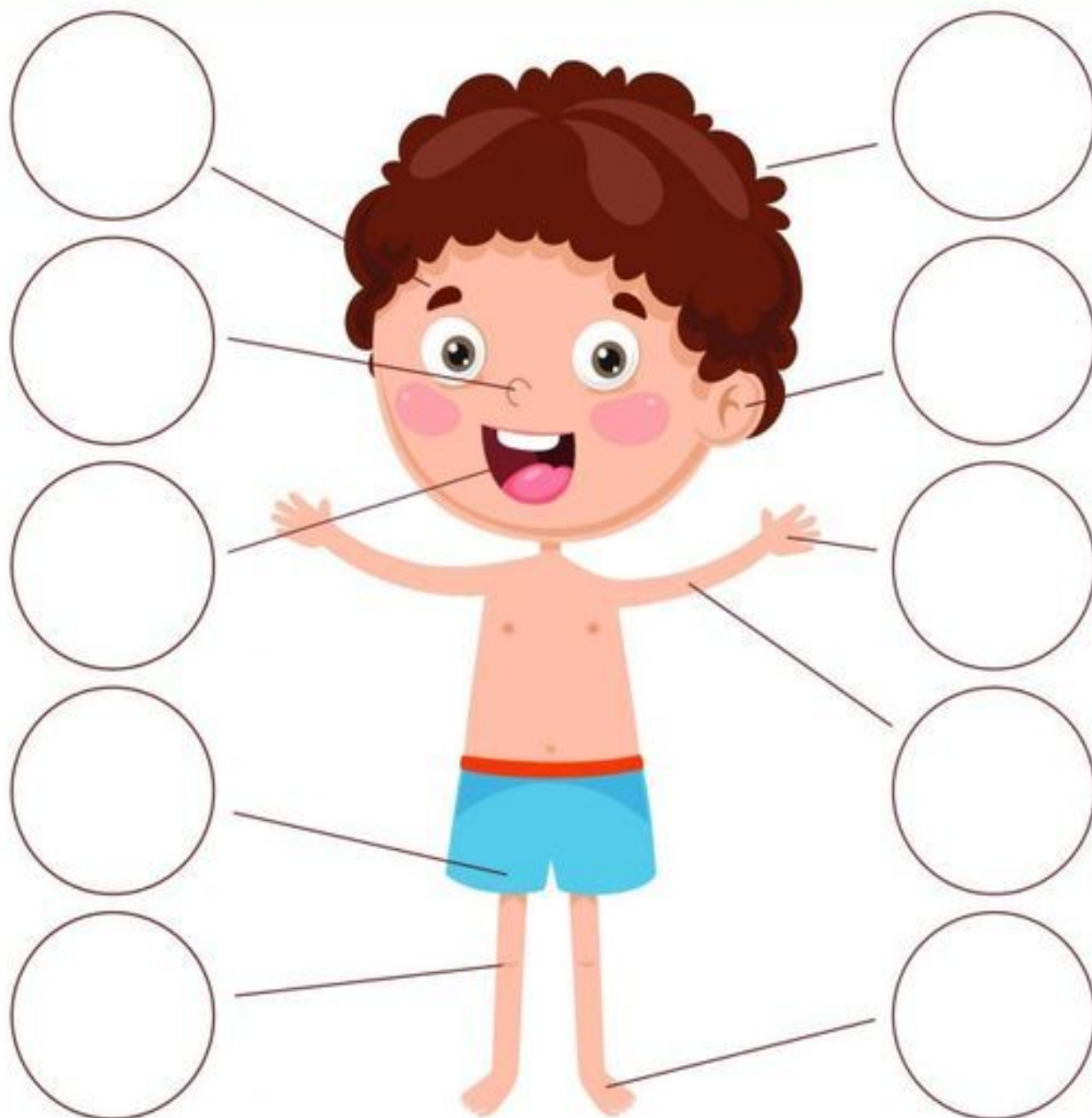

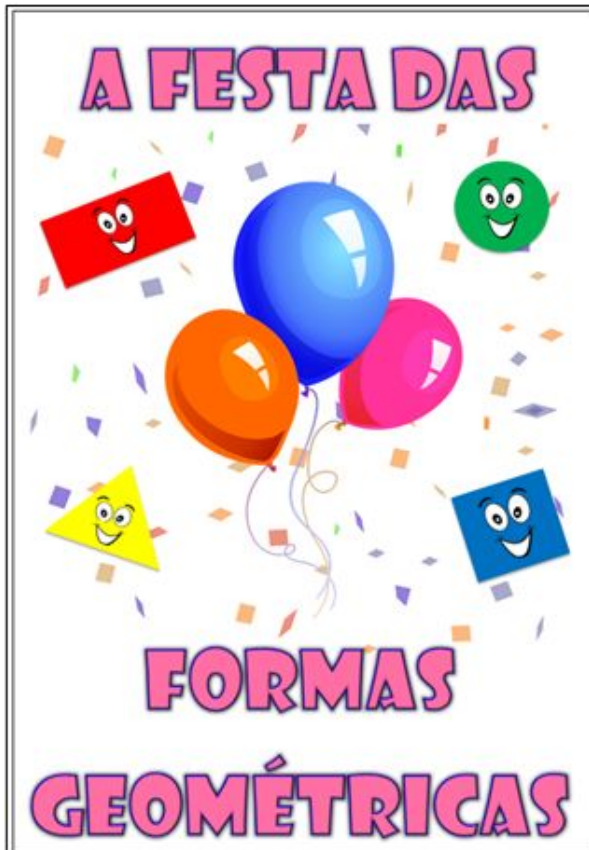

Ou até mesmo
automóvel.

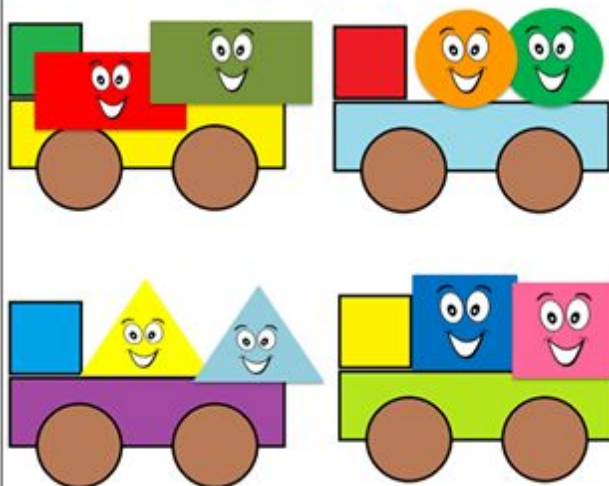

Um dia, todos se
encontraram de novo. E
aí, já haviam se
multiplicado...

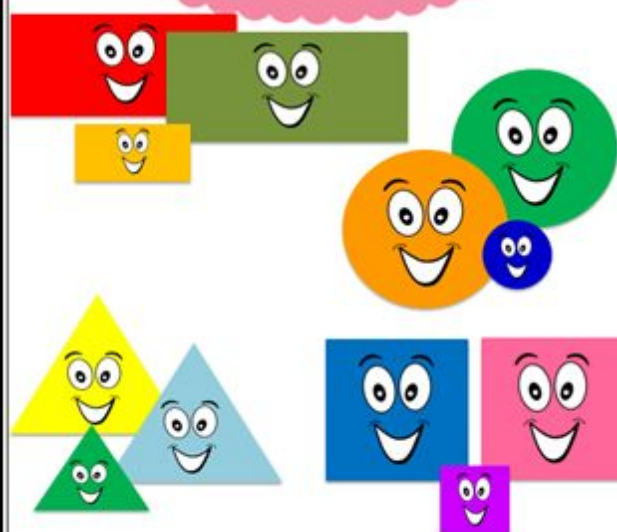

Foi uma festa!
Começou no
parque...

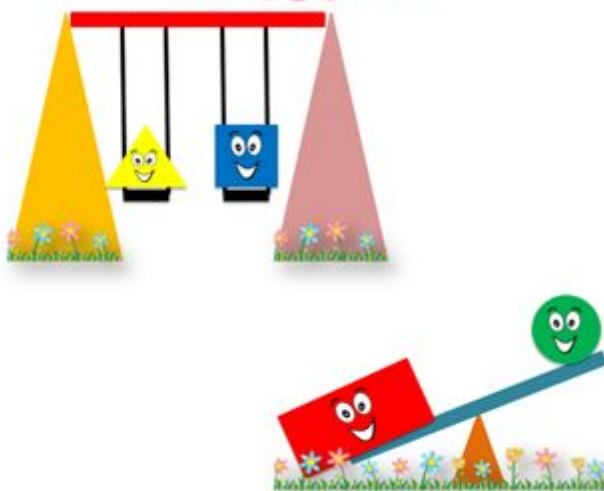

E terminou na
floresta.



VOCÊ JÁ PERCEBEU QUE PARA ONDE OLHAMOS EXISTE UMA FORMA GEOMÉTRICA? ELAS ESTÃO EM NOSSAS CASAS, NAS RUAS, NA ESCOLA, NAS PLACAS, NOS BRINQUEDOS ...

RECORTE AS IMAGENS DA **ATIVIDADE 2** E COLE AS FORMAS GEOMÉTRICAS NOS ESPAÇOS ADEQUADOS:

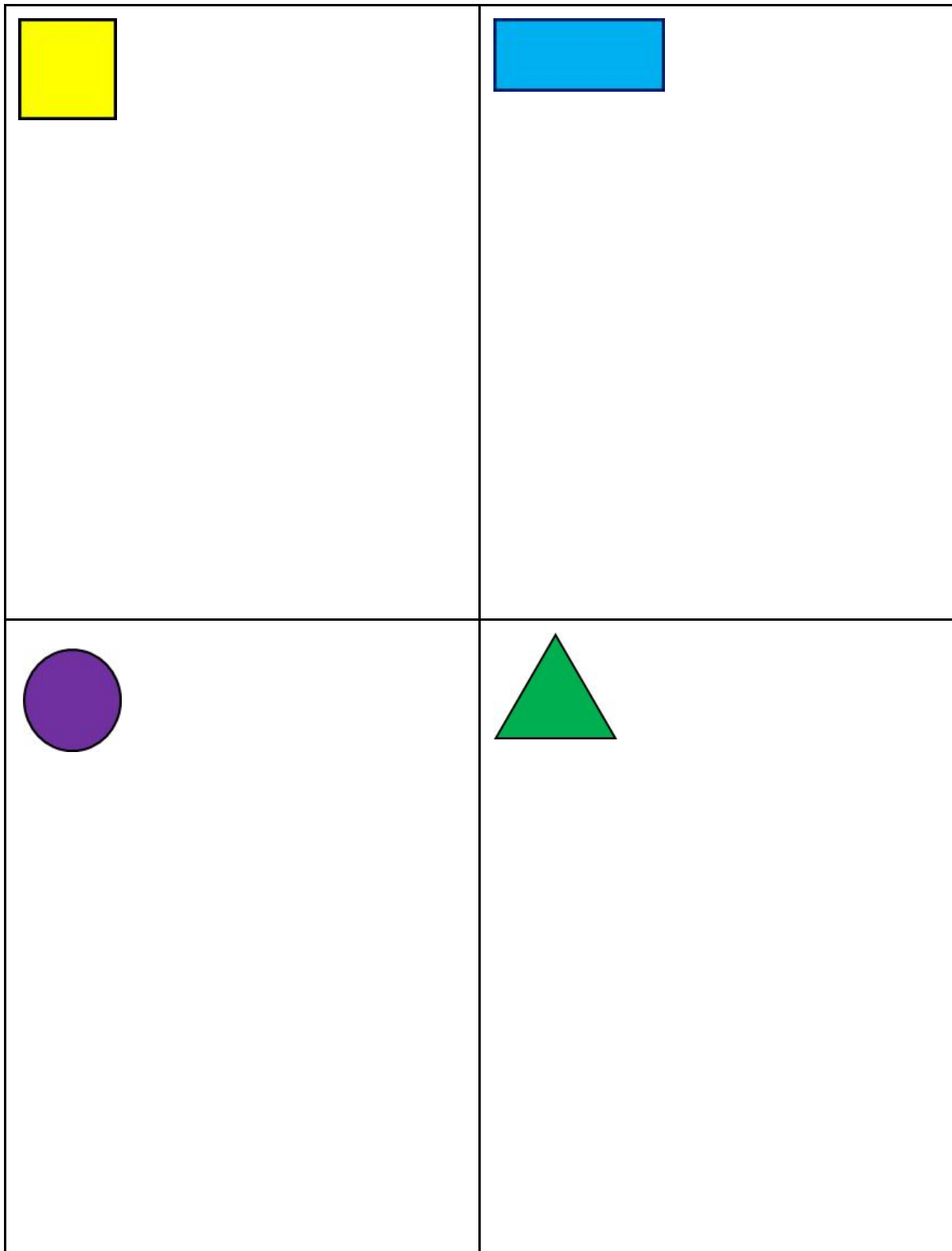

INGLÊS

JARDIM DE INFÂNCIA LUIZ GAMA

PROFESSORA: RAQUEL ADRIANA SOUZA

DATA: ____/____/____

ALUNO(A): _____

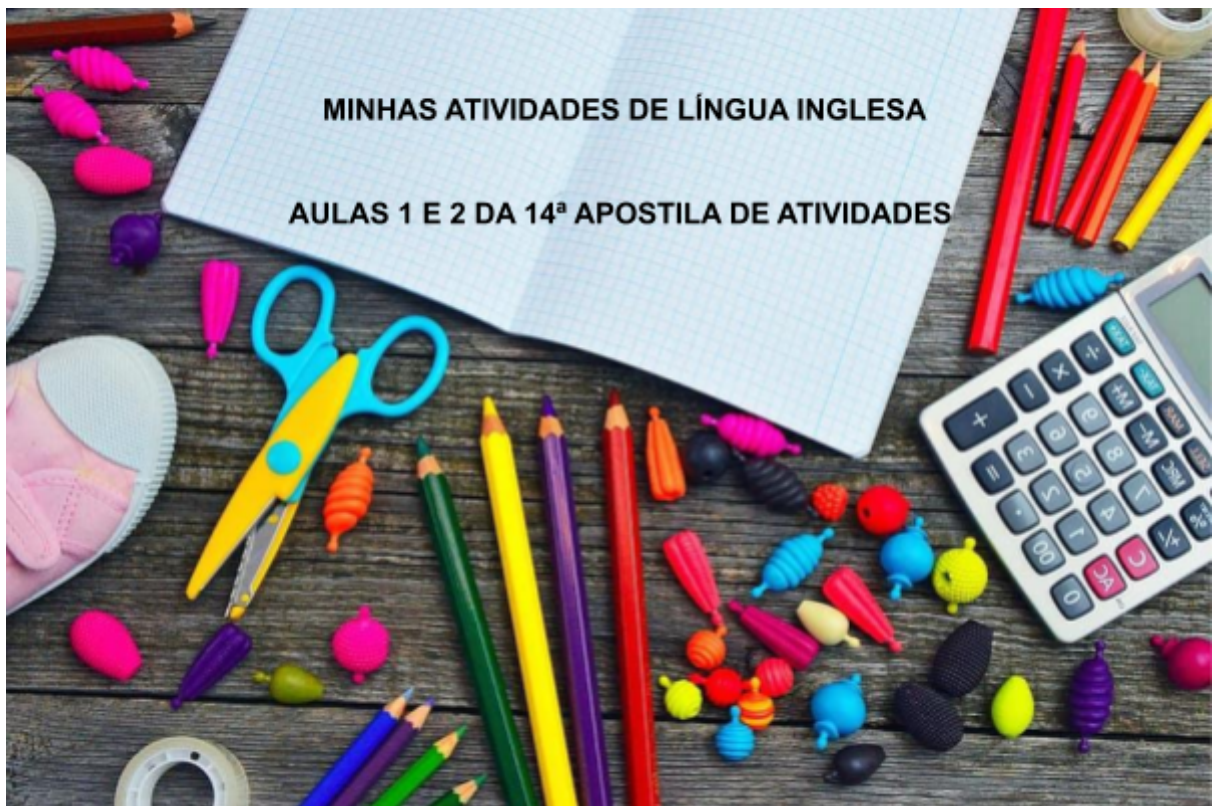

WATERMELON

(MELANCIA)

OLHE COM ATENÇÃO O PEDAÇO DE “WATERMELON” DA PÁGINA SEGUINTE E FAÇA UM X NO NÚMERO DE SEMENTES QUE VOCÊ OBSERVOU NA IMAGEM.

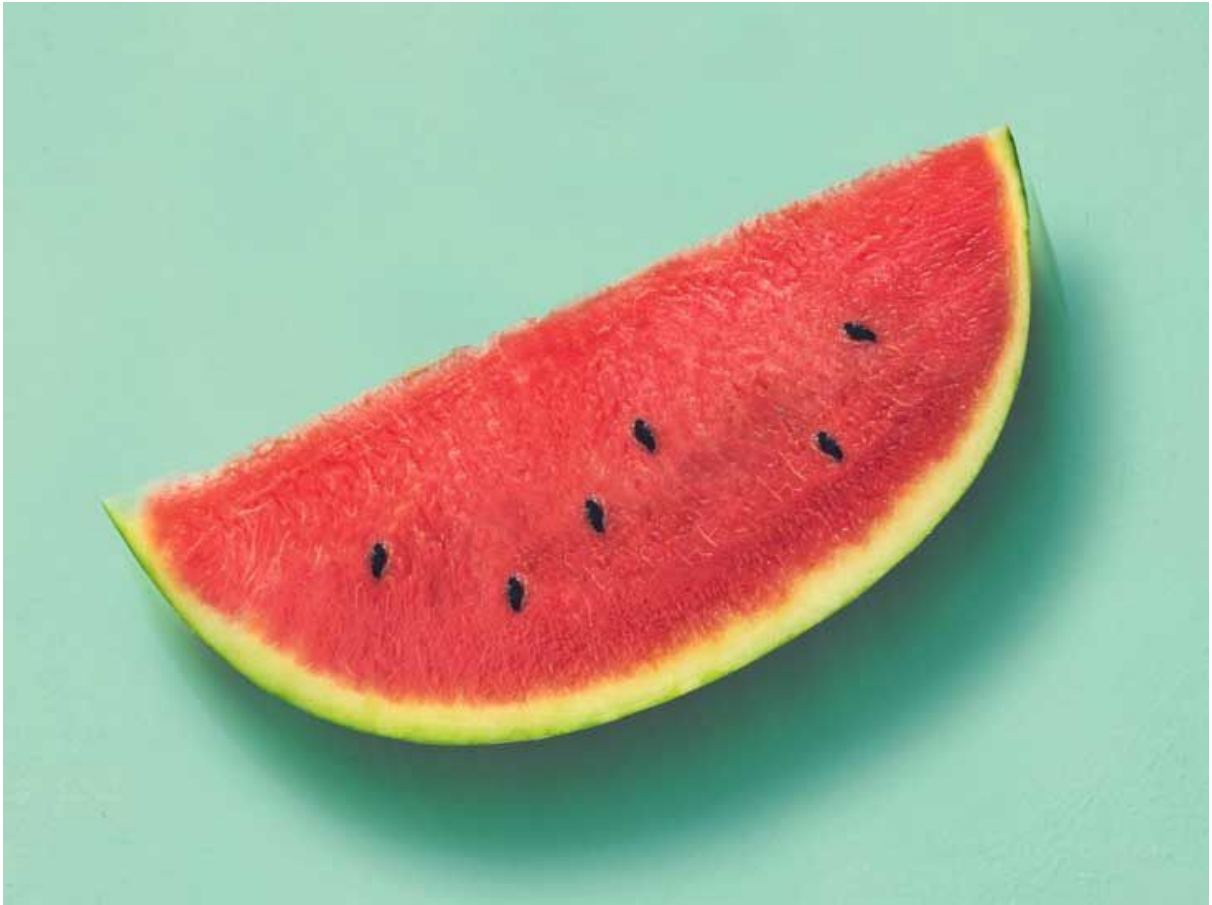

() 1 - ONE

() 2 - TWO

() 3 - THREE

() 4 - FOUR

() 5 - FIVE

() 6 - SIX

() 7 - SEVEN

() 8 - EIGHT

() 9 - NINE

() 10 - TEN

YARD (JARDIM)



AS FLORES EMBELEZAM QUALQUER AMBIENTE.

IMAGINE UM “YARD” (JARDIM) BEM BONITO E DESENHE NO QUADRO ABAIXO.

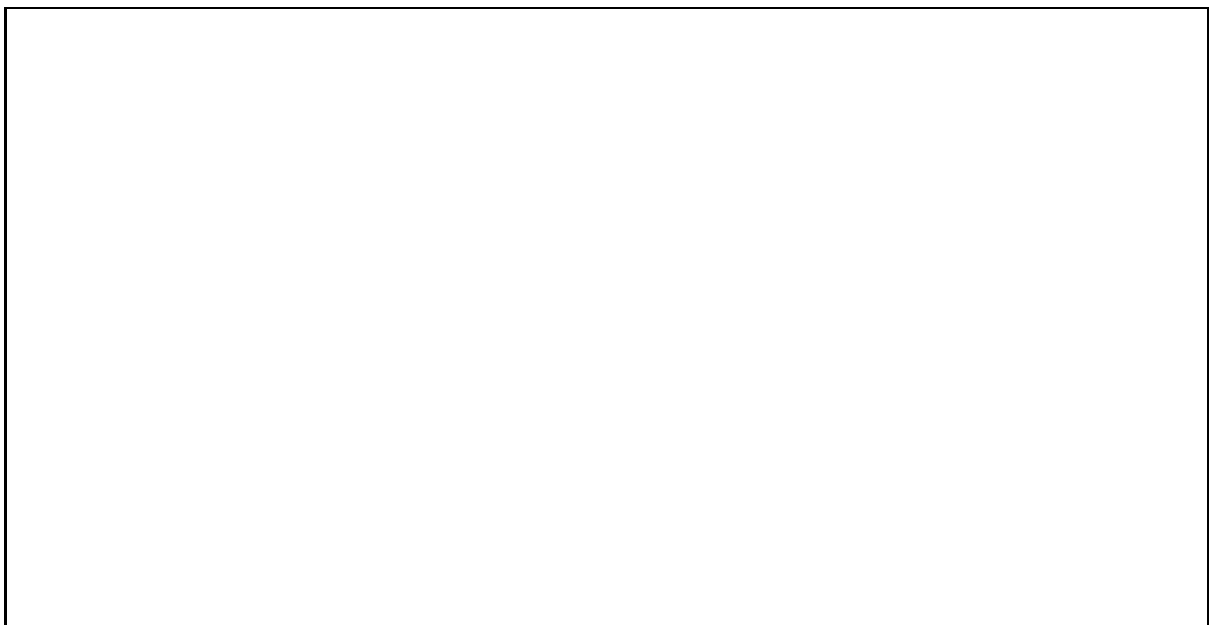

ARTE

CORONEL MARTINS, _____ DE _____ DE 2020

JARDIM DE INFÂNCIA LUIZ GAMA

PRÉ-ESCOLAR II (CRIANÇAS PEQUENAS) TURNO: VESPERTINO

PROFESSORA: **CARLA RAVARENA**

NOME: _____

OLÁ PAIS/RESPONSÁVEIS E AMADA **CRIANÇA**, TUDO BEM COM VOCÊS?
ESPERO QUE ESTEJAM TODOS BEM. **SAUDADES, BEIJINHOS DA
PROF^a.ARTE:CARLA RAVARENA.**

A PROFESSORA CARLA ESTÁ MUITO FELIZ EM PODER ESTAR ENVIANDO
PARA VOCÊ, A ATIVIDADE/EXPERIÊNCIA DE ARTE PARA VOCÊ REALIZAR EM
SUA CASA.

OBSERVAÇÃO:PAIS/RESPONSÁVEIS, SURGINDO DÚVIDAS NA HORA DE
REALIZAR A ATIVIDADE, FICO A DISPOSIÇÃO DE VOCÊS (GRUPO DA TURMA
NO WHATSAPP/TELEFONE (49)999421482.

14^a APOSTILA.

TEMA: **FORMAS GEOMÉTRICAS** – BRINCANDO COM OS PALITOS DE
PICOLÉ E MASSINHA DE MODELAR.

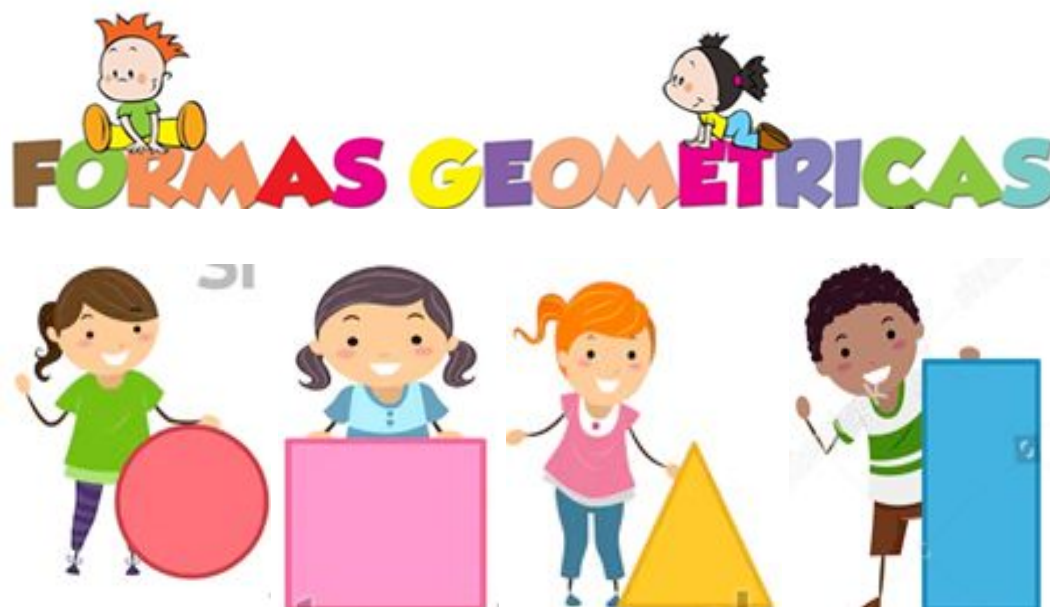

OLÁ AMIGUINHO(A)!

NÓS SOMOS AS FORMAS GEOMÉTRICAS!!



E QUEREMOS SABER O SEU NOME?

EU SOU O/A:

PAIS/RESPONSÁVEIS, AJUDE SEU/UA FILHO(A) ESCREVER O NOME NA LINHA ACIMA.

ATIVIDADE 1.

1- COM A AJUDA DE VOCÊS PAIS/RESPONSÁVEIS, NESSA ATIVIDADE/EXPERIÊNCIA A CRIANÇA VAI CONSTRUIR E REPRESENTAR AS FORMAS GEOMÉTRICAS UTILIZANDO OS PALITOS DE PICOLÉ PARA REPRESENTAR O **QUADRADO**, **RETÂNGULO** E **TRIÂNGULO** E A MASSINHA DE MODELAR PARA REPRESENTAR O **CÍRCULO**. PRIMEIRO, DEIXEM A CRIANÇA COLORIR OS PALITOS DE PICOLÉ COM OS LÁPIS DE COR, GIZ DE CERA, TINTA... O QUE VOCÊS TIVEREM E PUDEM DISPONIBILIZAR PARA ELE/ELA EM CASA (PALITOS DE PICOLÉ E MASSINHA DE MODELAR ENVIADA JUNTAMENTE COM A APOSTILA). DEPOIS QUE A CRIANÇA PINTOU OS PALITOS DE PICOLÉ, MOSTRE PARA A ELA A IMAGEM DE CADA UMA DAS FORMAS GEOMÉTRICAS QUE ESTÁ NA PÁGINA ANTERIOR E LEIA TAMBÉM O NOME DE CADA UMA DELAS PARA A CRIANÇA, NA SEQUÊNCIA, DISPONIBILIZE PARA ELA A MASSINHA DE MODELAR E OS PALITOS DE PICOLÉ (PALITOS DE PICOLÉ QUE ELE/ELA JÁ COLORIU) E AJUDE A CRIANÇA A CONSTRUIR E REPRESENTAR CADA UMA DAS FORMAS GEOMÉTRICAS UTILIZANDO O MATERIAL CITADO ACIMA. NÃO ESQUEÇAM QUE PARA QUE A CRIANÇA CONSIGA DESENVOLVER MELHOR ESSA EXPERIÊNCIA, VOCÊS PRECISAM DISPONIBILIZAR PARA ELE/ELA UMA BASE PLANA. EXEMPLO: MESA E OUTROS. **PAIS/RESPONSÁVEIS, VOCÊS NÃO PRECISAM DEVOLVER OS PALITOS DE PICOLÉ E MASSINHA DE MODELAR, ESSE MATERIAL É PARA A CRIANÇA MANUSEAR/EXPLORAR/BRINCAR EM CASA. DIVIRTA-SE AMADO(A) CRIANÇA!! NÃO ESQUEÇAM DE REGISTRAR COM FOTO/VÍDEO UM MOMENTO DESSA ATIVIDADE/EXPERIÊNCIA REALIZADA PELA CRIANÇA E ENVIAR NO GRUPO/WHATSAPP DA TURMINHA PARA QUE A PROFESSORA CARLA POSSA AVALIAR.**

ALGUNS EXEMPLOS DE FORMAS GEOMÉTRICAS CONSTRUÍDAS COM PALITOS DE PICOLÉ E MASSINHA DE MODELAR NAS IMAGENS ABAIXO, (É SÓ UM EXEMPLO, DEIXE QUE A CRIANÇA CRIE/CONSTRUA E EXPLORE ESSES MATERIAIS->MASSINHA/PALITOS E ESCOLHA AS CORES, PARA CONSTRUIR AS FORMAS GEOMÉTRICAS DA SUA MANEIRA E DA FORMA QUE QUISER/GOSTAR).

UTILIZANDO OS PALITOS DE PICOLÉ



UTILIZANDO A MASSINHA DE MODELAR



UTILIZANDO A MASSINHA DE MODELAR - REPRESENTAÇÃO DAS FIGURAS VAZADAS E COM VOLUME:

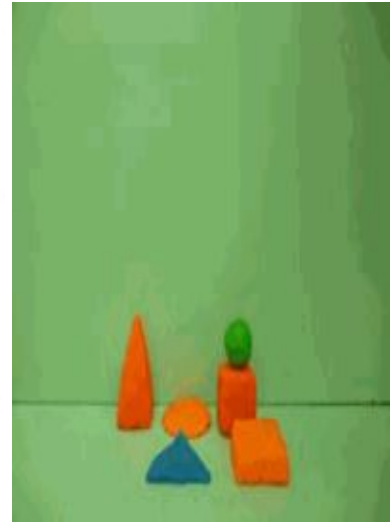
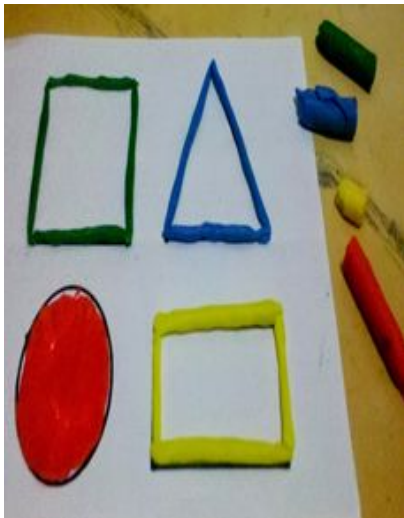

SUGESTÃO: PAIS/RESPONSÁVEIS, APÓS A CRIANÇA FAZER A EXPERIÊNCIA DE CONSTRUÇÃO DAS FORMAS GEOMÉTRICAS, VOCÊS PODEM PEDIR PARA QUE ELE/ELA TENHA TENTADO IDENTIFICAR ESSAS FORMAS GEOMÉTRICAS PRESENTES EM SI MESMO E EM TUDO O QUE NOS RODEIA. EXEMPLO: CORPO: CABEÇA, OLHOS... - NOS OBJETOS, UTENSÍLIOS, NATUREZA... E DEIXAR A CRIANÇA EXERCITAR AINDA MAIS A SUA CRIATIVIDADE ESTIMULANDO ELE/ELA, A CONSTRUIR/DESCONSTRUIR E REPRESENTAR DE VÁRIAS FORMAS/MANEIRAS O QUE ELA QUISER/GOSTAR. EXEMPLO: PESSOA, CASA, ÁRVORE, CARRINHO, E MUITOS OUTROS.

MARAVILHOSA AULA AMADO(A) CRIANÇA, AMO MUITO VOCÊ!!!



PROFESSORA DE ARTE: CARLA RAVARENA.

DANÇA - TURMA: PRÉ II

DATA: ____/____/____.

GRUPO ESCOLAR MUNICIPAL MONTEIRO LOBATO.

PROFESSORA: LORECI M. G. POZZER.

ALUNO (A): _____

AULAS 01 E 02 - 14ª APOSTILA.

VAMOS NOS MOVIMENTAR?



OLÁ CRIANÇAS! TUDO BEM COM VOCÊS? HOJE VOCÊ IRÁ DANÇAR UMA MÚSICA PARA ESTIMULAR SEUS MOVIMENTOS, SEU EQUILÍBRIO E A SUA COORDENAÇÃO MOTORA. VAI SER DIVERTIDO E FÁCIL, É SÓ SEGUIR O QUE DIZ NA MÚSICA. VOCÊ, O PAPAÍ, A MAMÃE E TODA A SUA FAMÍLIA PODERÃO DANÇAR E BRINCAR COM VOCÊ!

- SE TIVER ACESSO A INTERNET, DIGITE O NOME DA MÚSICA NO YOUTUBE: **“PULE E PARE | EU AMO APRENDER | MÚSICAS PARA CRIANÇAS | PLAYKIDS”**. LINK: https://www.youtube.com/watch?v=wiOyoY_WOfA.
- SE NÃO TIVER ACESSO A INTERNET, LEIA A MÚSICA PARA A CRIANÇA REALIZAR OS MOVIMENTOS COMO PEDE. E DIVIRTAM-SE!
- MANDE VÍDEO OU FOTO DE VOCÊ DANÇANDO. A PROFª VAI ADORAR!

PULE E PARE

PLAYKIDS

VEM BRINCAR DE PULE E PARE

É SÓ PULAR COMO UM COELHO QUANDO EU DISSER PULE

E DEPOIS CONGELAR QUANDO EU DISSER PARE

ESSE É O PULE E PARE

PULE COM SUA PERNA DIREITA
PONHA O DEDO NA PONTA DO NARIZ ASSIM
PULE, PULE, PULE COM SUA PERNA DIREITA
AGORA EU VOU PEDIR PRA PARAR

PULE COM SUA PERNA ESQUERDA
PULE, PULE E PONHA A MÃO NA CABEÇA
PULE, PULE, PULE COM SUA PERNA ESQUERDA
AGORA EU VOU PEDIR PRA PARAR

AGORA PULE, PARE
PULE, PARE
PULE, PULE E DÊ UMA VOLTINHA
IMITE O SOM E O JEITO DA GALINHA

PULE COM AS SUAS DUAS PERNAS
AGORA EU VOU PEDIR PRA PARAR

AGORA PULE, PARE
PULE, PARE
PULE, PARE

VIVA, TODO MUNDO PULOU E PAROU,
PRA CIMA E PRA BAIXO QUANDO EU DISSE PULE
E QUANDO EU DISSE PARE TUDO CONGELOU
ESSE É O PULE E PARE (3X)

PARABÉNS! 🙌🙌🙌

ATIVIDADES

1. MUITO BEM! AGORA QUE JÁ DANÇOU, CONTE PARA A PROFESSORA COMO VOCÊ SE SENTIU AO DANÇAR. PARA ISSO, PINTE O EMOJI QUE MOSTRA O SEU SENTIMENTO:

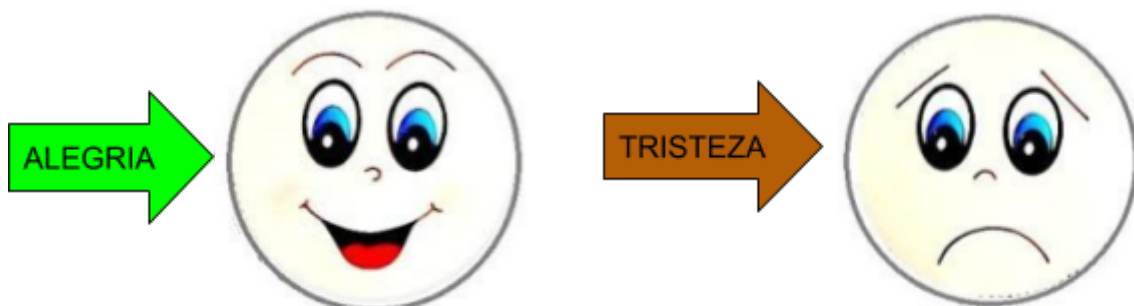

2. VAMOS LEVAR CADA ANIMAL AO SEU ALIMENTO? PARA ISSO, PEGUE O LÁPIS E CONTINUE DESENHANDO O CAMINHO. MAS ATENÇÃO, OBSERVE QUE CADA ANIMAL FAZ UM CAMINHO DIFERENTE.



3. AGORA, PEGUE A FOLHA ONDE ESTÁ ESCRITO **ANEXO: AULA DE DANÇA** E RECORTE O DADO. DEPOIS SE POSSÍVEL, COLAR O DADO EM UM PAPEL MAIS FIRME (ASSIM O DADO IRÁ FICAR MAIS RESISTENTE) POR EXEMPLO: CAPA DE LIVRO PARA RECORTE, CARTOLINA OU OUTRO MATERIAL QUE TIVER E QUE POSSA SER USADO. QUANDO SECAR, RECORTE NOVAMENTE E MONTE O DADO. DEPOIS, CONVIDE SUA FAMÍLIA PARA BRINCAR COM VOCÊ. JOGUE O DADO E FAÇA O MOVIMENTO QUE FICAR VIRADO PARA CIMA. BRINQUE E DIVIRTA-SE!

ED. FÍSICA

JARDIM DE INFÂNCIA LUIZ GAMA

PROFESSOR: CARLOS ALEXANDRE PICCHI

CORONEL MARTINS, _____ DE _____ DE 2020

NOME DO ALUNO: _____ TURMA: PRÉ II

EDUCAÇÃO FÍSICA - 2020

ATIVIDADE 1: O MESTRE MANDOU: O PAI OU A MÃE DARÁ AS ORDENS E A CRIANÇA DEVERÁ CUMPRIR-LA DESDE QUE SEJAM PRECEDIDAS DAS PALAVRAS DE ORDEM: "O MESTRE MANDOU": EXEMPLOS : PULAR DE UM PÉ SÓ, GIRANDO E BATENDO PALMA!; PULAR IGUAL COELHO, SAPO ESSES SÃO ALGUNS EXEMPLOS.

ATIVIDADE 2: LIGUE OS ANIMAIS ÀS SUAS SOMBRAS:

RELACIONE OS ANIMAIS ÀS SUAS SOMBRAS



ATIVIDADE 3: CABRA - CEGA: DE OLHOS VENDADOS, A CRIANÇA DEVERÁ PEGAR OS MEMBROS DA FAMÍLIA, DEPOIS QUE PEGAR DEVERÁ TENTAR ADIVINHAR QUEM PEGOU: EX: SE FOI PEGO O PAI, MÃE, IRMÃO (AVÔ OU AVÓ).

ATIVIDADE 4: AJUDE A ABELHA A ENCONTRAR A FLOR:

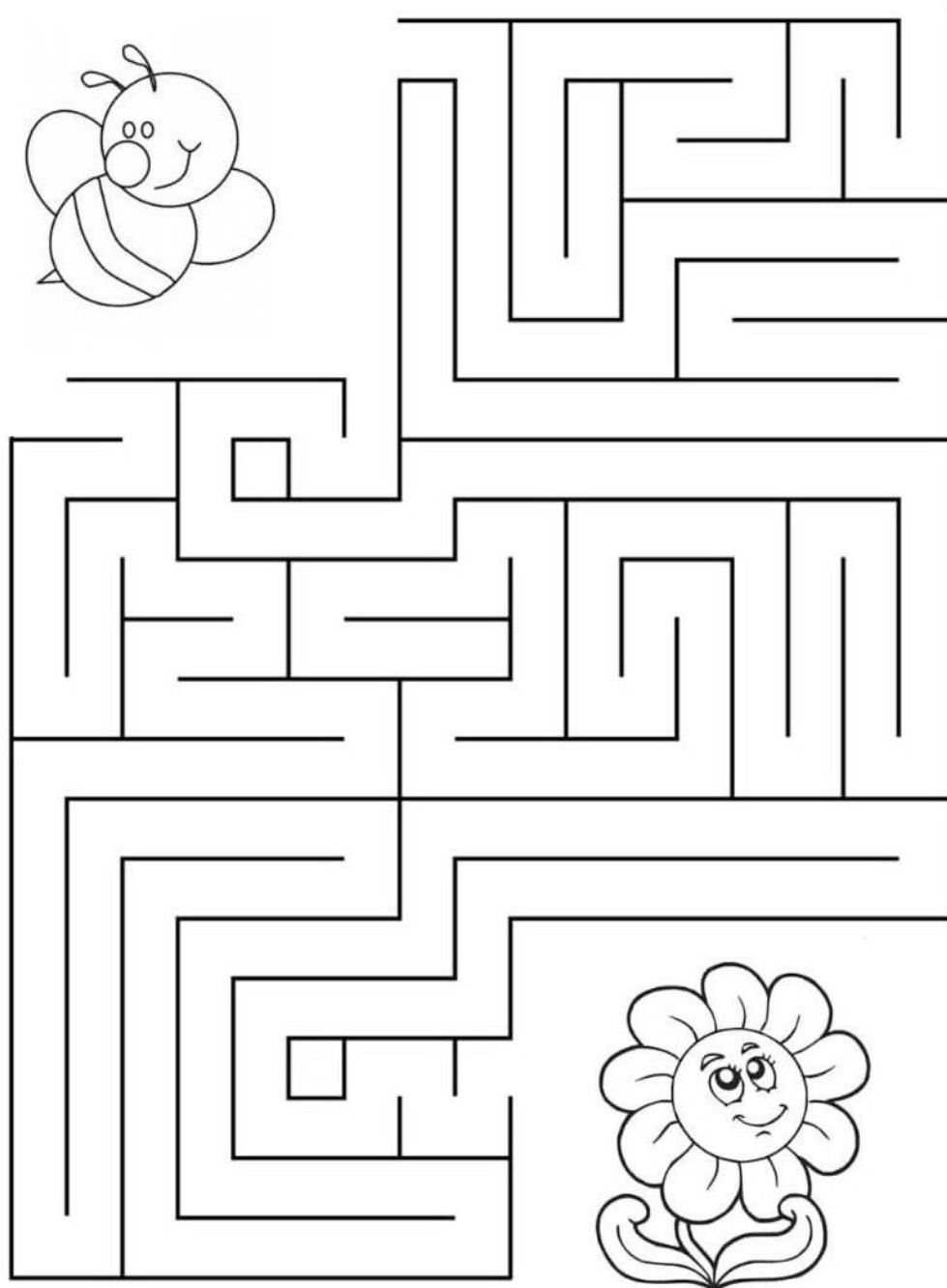

ATIVIDADE 5: BOLICHE: DESENHAR UM QUADRADO OU UM CÍRCULO NO CHÃO PARA ARRUMAR OS LITROS. AS CRIANÇAS TOMARAM UMA DISTÂNCIA (OS RESPONSÁVEIS PODEM VARIAR A DISTÂNCIA COMEÇA DE PERTO DEPOIS VAI DEIXANDO MAIS LONGE) COM UMA BOLA TENTARAM DERRUBAR OS LITROS.

ATIVIDADE 6: COBRINHA: COM UMA CORDA NO CHÃO COMECE A MEXER A CORDA COMO SE FOSSE UMA "COBRA" A CRIANÇA DEVERÁ PULAR A CORDA SEM ENCOSTAR NA CORDA QUE SERÁ A "COBRINHA".

ATIVIDADES DE REVISÃO:

1. VAMOS LIGAR OS PONTOS?



NÃO IMPRIMIR NO VERSO

ATIVIDADE 02: RECORTE O DOMINÓ E JOGUE COM A FAMÍLIA.

	PRESENTE		GALINHA
	BORBOLETA		BRIGADEIRO
	FORMIGA		BISCOITO
	PALHAÇO		PENTE
	CAMINHÃO		ABELHA
	CACHORRO		SORVETE
	SERROTE		CHAPÉU
	NINHO		CORDA
	OSSO		COBRA
	JARRA		TIGRE

NÃO IMPRIMIR NO VERSO

NÃO PRECISA DEVOLVER

ATIVIDADE 1



ATIVIDADE 2



ANEXO: AULA DE DANÇA

(OBS: NÃO IMPRIMIR NO VERSO DESTA FOLHA)

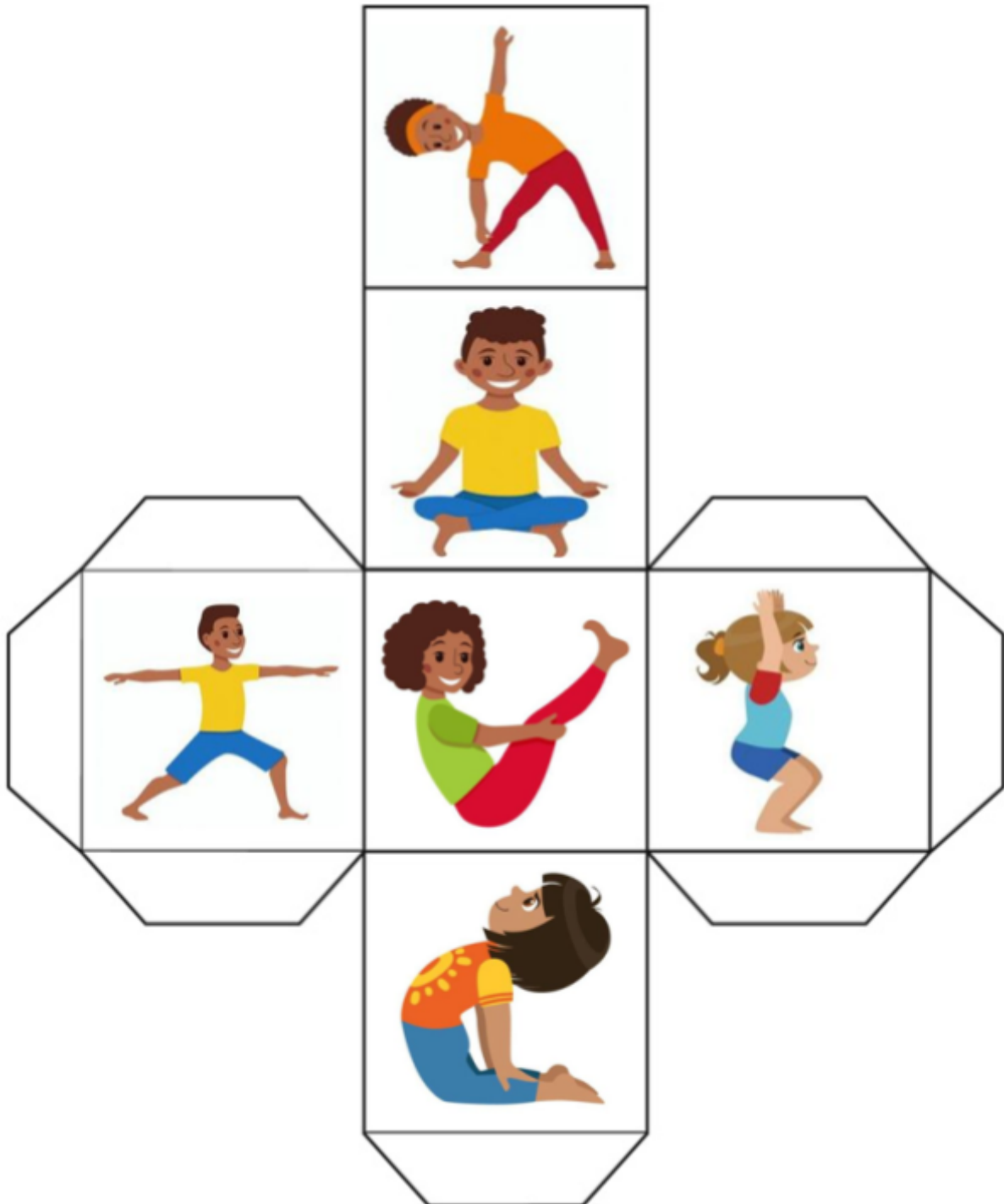

NÃO PRECISA DEVOLVER O DADO

